

ACSD050-120051 Motor Controller



FEATURES

- **Open-Loop Speed Control**
- **40 to 120 VAC 50/60Hz Input**
- **Variable Speed Control**
- **Compact Package**
- **Easy to Use and Cost Effective**
- **Quick Disconnect for Easy Connections**
- **Onboard Run/Stop Option**
- **Efficient and Durable**
- **Can be made custom for specific applications**



DESCRIPTION

The ACSD050-120051 is a Solid State AC Motor Control. The open-frame design allows for various mounting positions and easy access and installation of disconnects for motor and power input. It operates from 40VAC up to 120VAC, 50/60 Hz and is capable of 5.0 Amps RMS @ 50°C. With proper heatsinking, higher operating currents can be obtained. The ACSD050-120051 provides variable speed control for Shaded Pole, Permanent Split Capacitor Motor, Capacitor Run Motor, and Universal Motors. The ACSD050-120051 provides a basic form of speed control and an option to incorporate a Run/Stop switch. Applications include range hoods, vibrators, humidifiers, fireplace blowers, fans, laminar flow hoods, heat tunnels and stirrers.

DIMENSIONS

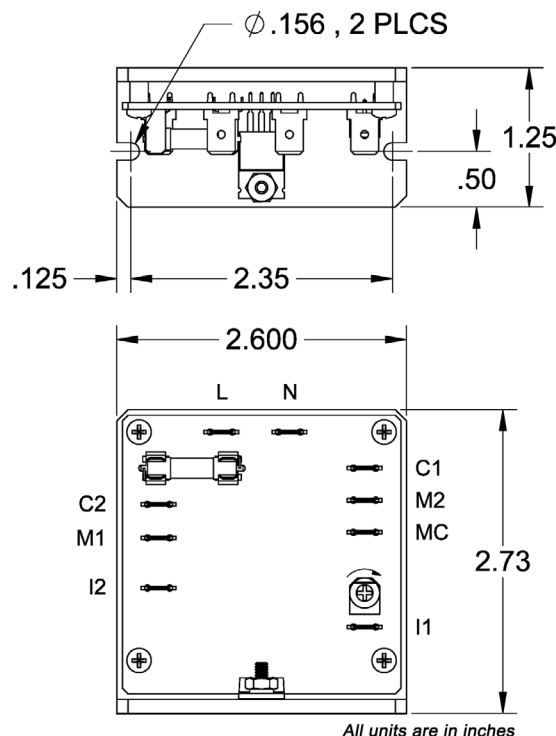

L010670

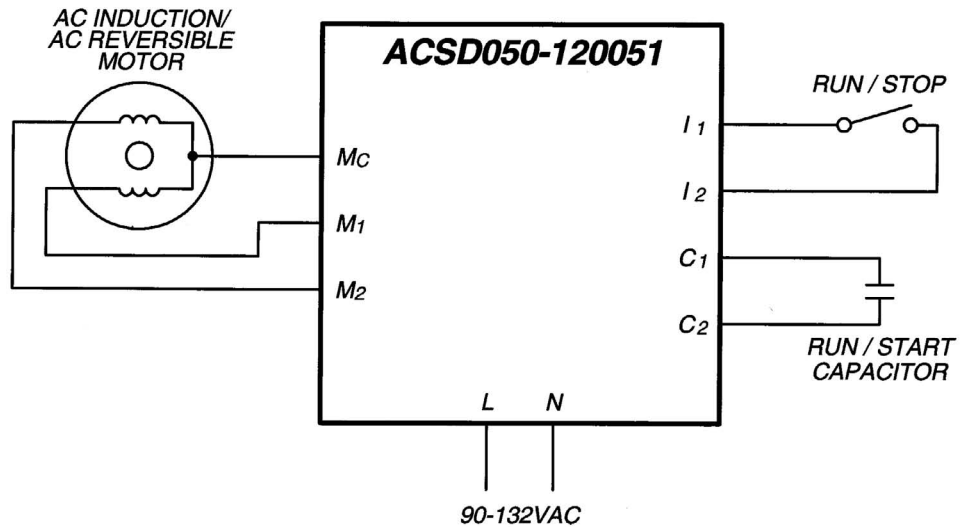

For other motor connections, such as a universal motor or other 2 wire connections, connect the leads to the MC and M1 quick disconnects. If doing so, please cover the M2, C1 and C2 connections to avoid any serious injury or shock.

Specifications

The ACSD050-120051 is a simple phase control driver which varies the effective RMS line voltage. The torque developed by an induction motor is proportional to the square of the applied voltage. If the load has a torque-speed characteristic such as shown in Figure 1, the the speed of the motor can be controlled over a small range by varying the line voltage This curve is not to be confused with a universal type motor.

Variable-line-voltage speed control in an induction motor.

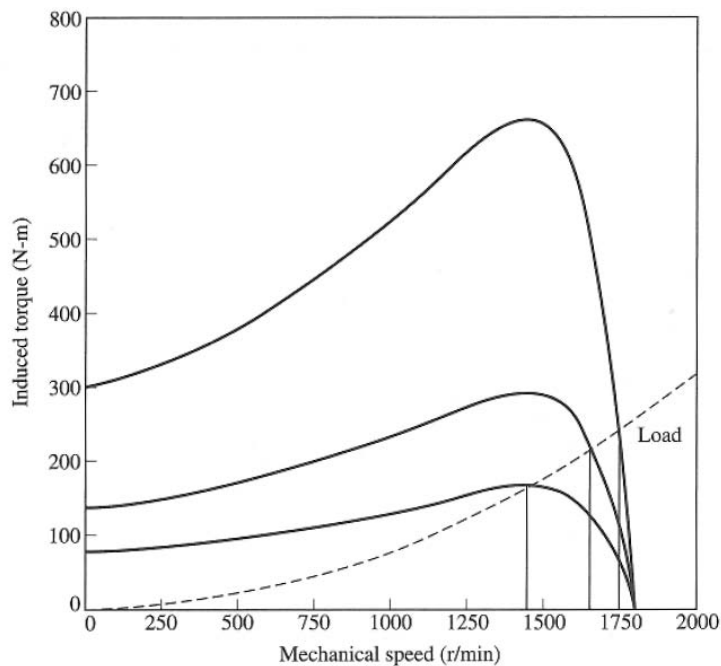

Figure 1